



Figure # 246

Brass Swing Check Valve (1/2"-4")

Product Features

- 200# WOG
- Brass Body
- Brass Seats
- Threaded Ends
- Horizontal "T" pattern



Pressure/Temperature Ratings

200# WOG

450 degrees F. max temp.

Materials & Specifications

Item	Description	Material	Specification
1	Body	Brass	B584 C85400
2	Cap	Brass	B584 C85400
3	Disc	Brass	B584 C85400
4	Hanger Pin	Brass	B124 C37700
5	Plug	Brass	B16 C36000

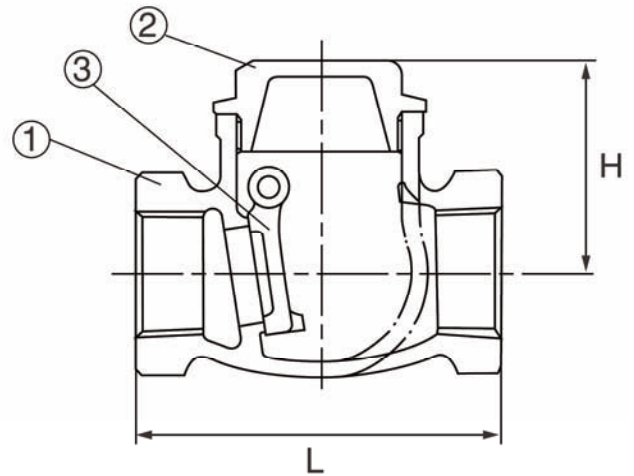

Dimensions, Weights (inches-lbs.) & Valve Data

Size	1/2	3/4	1	1-1/4	1-1/2	2	2-1/2	3	4
H	2.12	2.3	2.6	3	3.4	4.2	5	6	7.6
L	2	2.36	2.6	3.2	3.5	4.2	5.1	5.8	6.8
Wt.- lbs.	.5	.67	.88	1.48	2	2.8	5.5	7.75	12.75

