

Lead Free Brass Threaded Water Heater Isolation Valve Kit

Feature

- 600# WOG (non-shock)
- Lead free brass construction
- ¼ turn operation
- Full port
- Adjustable packing
- Blow-out proof stem
- FNPT end x FNPT tailpiece (ASME B1.20.1-NPT)
- AB1953, NSF/ANSI/CAN 61 & 372 certified

3321AB: Hot valve operation (red handle)
 3322AB: Cold valve operation (blue handle)



Material

	Part	Material	Specification
1	Body	Lead Free Brass	ASTM B927 C27450
2	Fixed end	Lead Free Brass	ASTM B927 C27450
3	Ball	Lead Free Brass / Cr plated	ASTM B927 C27450
4	Seat	PTFE	PTFE
5	Stem	Lead Free Brass	ASTM B927 C27450
6	Packing ring	PTFE	PTFE
7	Packing nut	Brass	ASTM B283 C37700
8	T-handle *	Aluminum	ASTM B85
9	Handle nut	Steel /Zn plated	ASTM A36
10	Union nut	Brass	ASTM B283 C37700
11	Union	Lead Free Brass	ASTM B927 C27450
12	O-ring	EPDM Perox	NSF approved

*3321AB: Red, 3322AB: Blue

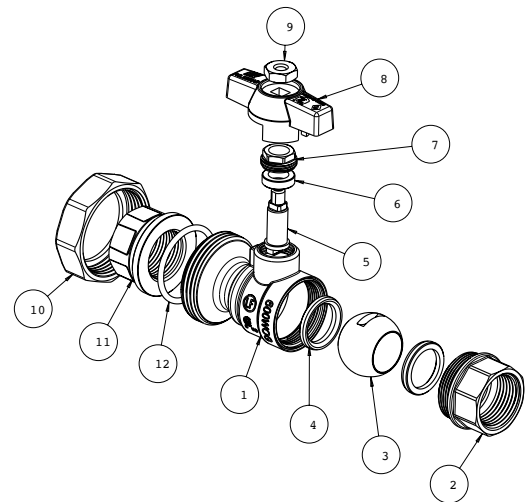

Dimension, Weight

Size	Φ [in]	A [in]	H [in]	P [in]	Wt. [lb]
¾"	¾ - 14 NPT	3.54	1.66	0.73	0.92

