

### Feature

Electric actuator with ISO 5211 connection  
 Double insulated cover according CEI/EN 60335-1  
 Max torque 11.1 ft-lb, working torque 5.90 ft-lb  
 Travel 90° in 60 seconds  
 Manual override, integral heater  
 F05 connection, stem connection  $\square$ 0.35 inch or  $\square$ 0.43 inch  
 With 31.5 inch electric wire  
 Enclosure protection IP65



Power supply 50Hz/60Hz, 24VAC  
 3 points control  
 Auxiliary dry open limit switch (Max 230 VAC / 6A)

Working temperature: 15 °F to 160 °F

Meet BAA requirement

### Technical data

RWV code	P. Supply	Control	Power
SLOOP2-024-3PT-0	24VAC	3 points	5W

### Dimension (inch), Weight

Weight: 1.76lb

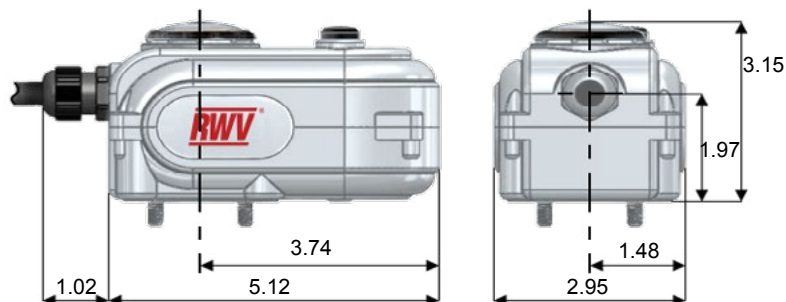

### Wiring Diagram

Ref.	Designation
OXS	Auxiliary open limit switch
T	Control switch (thermostat)
H	Integral heater
N	Wiring to neutral
Ph	Wiring to phase

